

**LBT PROJECT
2x8.4m TELESCOPE**

Doc.No. : 675s008
Issue : a
Date : 13-March-2007

**LBT PROJECT
2 X 8.4m OPTICAL TELESCOPE**

**Instrument Rotator and Cable Chain
Electrical Connection Manual**

	Signature	Date
Prepared	Mike Gusick	13 March 2007
Reviewed	David Ashby	19 March 2007
Approved		

1. Revision History

Issue	Date	Changes	Responsible
a	13-Mar-07	First draft	Mike Gusick

	<p style="text-align: center;">Instrument Rotator and Cable Chain Electrical Connection Manual</p>	<p>Doc.No : 675s008 Issue : a Date : 13-Mar-2007</p>	<p style="text-align: center;">Page 3</p>
--	--	--	---

2. Table Of Contents

1.	Revision History	2
2.	Table Of Contents	3
3.	About this document	4
3.1.	Reference Documents	4
3.2.	Abbreviations	4
4.	Introduction.....	5
4.1.	Instrument Rotator and Cable Chain Electrical Equipment.....	5
5.	Bent Gregorian Rotators	5
6.	Direct Gregorian Rotators.....	10

	<p style="text-align: center;">Instrument Rotator and Cable Chain Electrical Connection Manual</p>	<p>Doc.No : 675s008 Issue : a Date : 13-Mar-2007</p>	<p style="text-align: center;">Page 4</p>
--	--	--	---

3. About this document

This document will describe the electrical connection of components for instrument rotators and cable chains.

3.1. Reference Documents

- [RD1] CAN 675s005a – Instrument Rotator and Cable Chain Power Drive Module Description and Operations Manual
- [RD2] CAN 675s004a – Instrument Rotator and Cable Chain Interface Module Description and Operations Manual
- [RD3] CAN 561s003 - Elevation Utilities Electrical Power Supply Requirements
- [RD4] CAN 504s003 - Telescope Tree Houses--Equipment Rack Definitions

3.2. Abbreviations

B/D	Bent/Direct
CAN	Controller Area Network
F/C/R	Front/Center/Right
I/O	Input-Output
L/R	Left/Right
MCR	Master Control Relay
MCS	Mount Control System

	Instrument Rotator and Cable Chain Electrical Connection Manual	Doc.No : 675s008 Issue : a Date : 13-Mar-2007	Page 5
--	--	---	--------

4. Introduction

The purpose of this document is to define the systems level connection of the instrument rotators and cable chain electrical equipment. See [RD1] [RD2] [RD3] [RD4] for a detailed description of major components and location on the elevation axis.

4.1. Instrument Rotator and Cable Chain Electrical Equipment

The operation of each instrument rotator and associated cable chain requires several components to be electrically connected for proper operation. The instrument rotator and cable chain electrical equipment is installed in two major areas on the telescope 1) upper tree houses on the elevation axis 2) near each instrument rotator axis.

5. Bent Gregorian Rotators

Figure 1 shows the electrical connections for 1 axis of a bent Gregorian instrument rotator and cable chain. Table 1 through Table 6 list the cables required for connection of the electrical equipment on bent Gregorian rotators.

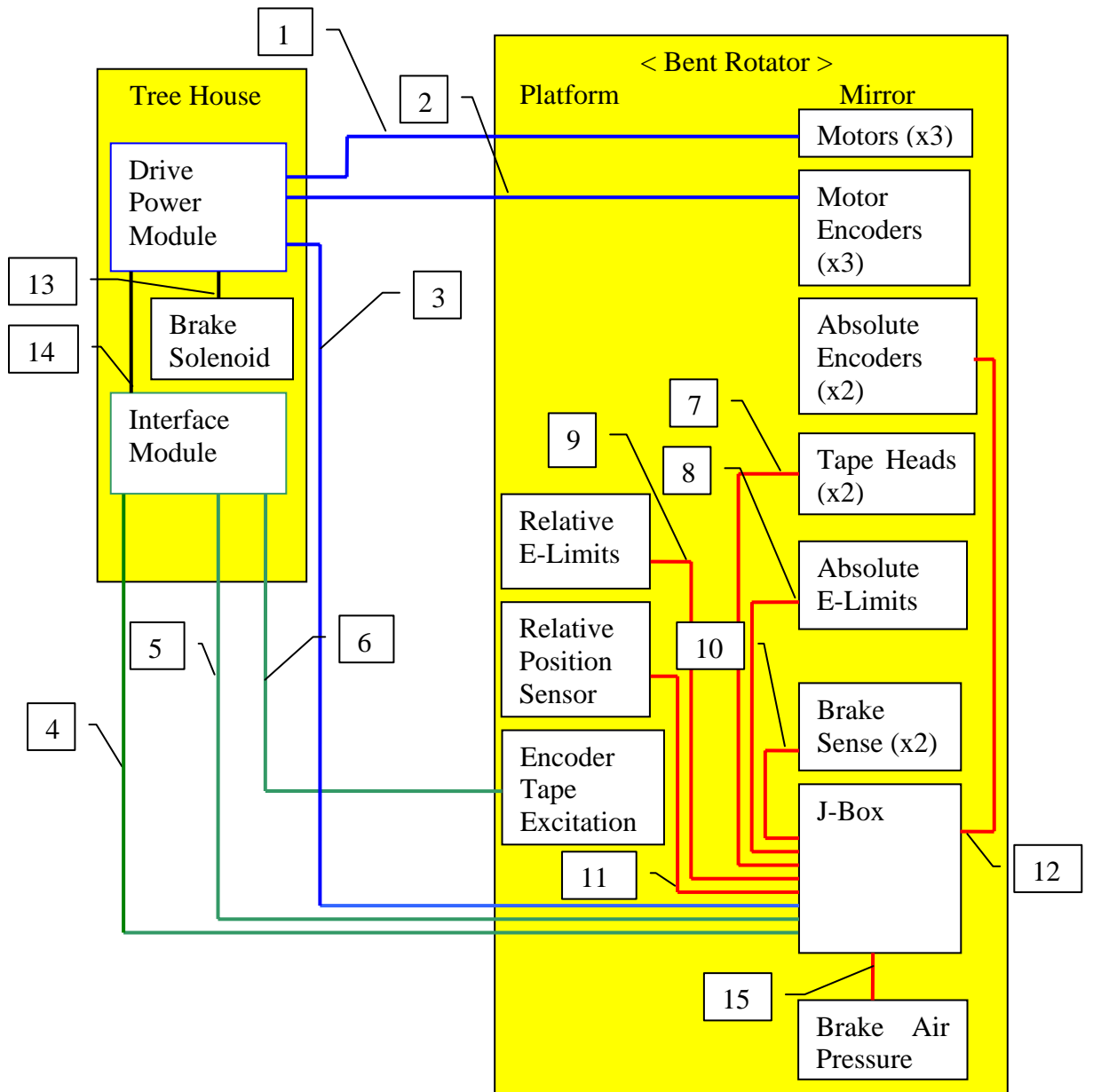

Figure 1

Cable Designator - (L/R)(F/C/R)(B/D)(Cable Number)

Table 1

Callout	Cable Designator	Description
1	LFBC1	Drive Module Rotator Motor 0
1	LFBC2	Drive Module Rotator Motor 1
1	LFBC3	Drive Module Cable Chain Motor
2	LFBC4	Drive Module Rotator ENDAT Encoder 0
2	LFBC5	Drive Module Rotator ENDAT Encoder 1
2	LFBC6	Drive Module Cable Chain ENDAT Encoder
3	LFBC7	Drive Power Module Emergency Limits
4	LFBC8	Interface Module Rotator Absolute Encoders, Brake Sense
5	LFBC9	Interface Module Tape Read Heads, Relative position Sensor, 2 Aux 4-20ma Inputs
6	LFBC10	Interface Module Tape Excitation
7	LFBC11	J-Box Tape Read Head 0
7	LFBC12	J-Box Tape Read Head 1
8	LFBC13	J-Box Absolute CCW/CW Emergency Limits
9	LFBC14	J-Box Relative CCW/CW Emergency Limits
10	LFBC15	J-Box Brake Sense 0
10	LFBC16	J-Box Brake Sense 1
11	LFBC17	J-Box Relative Position Sensor
12	LFBC18	J-Box Absolute Encoder 0
12	LFBC19	J-Box Absolute Encoder 1
13	LFBC20	Drive Power Module Brake Release Solenoid
14	LFBC21	CAN Communication
14	LFBC22	Analog Input
14	LFBC23	Digital I/O and Power
14	LFBC24	Encoder Quadrature
15	LFBC25	Brake Air Pressure

Table 2

Callout	Cable Designator	Description
1	LCBC1	Drive Module Rotator Motor 0
1	LCBC2	Drive Module Rotator Motor 1
1	LCBC3	Drive Module Cable Chain Motor
2	LCBC4	Drive Module Rotator ENDAT Encoder 0
2	LCBC5	Drive Module Rotator ENDAT Encoder 1
2	LCBC6	Drive Module Cable Chain ENDAT Encoder
3	LCBC7	Drive Power Module Emergency Limits
4	LCBC8	Interface Module Rotator Absolute Encoders, Brake Sense
5	LCBC9	Interface Module Tape Read Heads, Relative position Sensor, 2 Aux 4-20ma Inputs
6	LCBC10	Interface Module Tape Excitation
7	LCBC11	J-Box Tape Read Head 0
7	LCBC12	J-Box Tape Read Head 1
8	LCBC13	J-Box Absolute CCW/CW Emergency Limits

9	LCBC14	J-Box Relative CCW/CW Emergency Limits
10	LCBC15	J-Box Brake Sense 0
10	LCBC16	J-Box Brake Sense 1
11	LCBC17	J-Box Relative Position Sensor
12	LCBC18	J-Box Absolute Encoder 0
12	LCBC19	J-Box Absolute Encoder 1
13	LCBC20	Drive Power Module Brake Release Solenoid
14	LCBC21	CAN Communication
14	LCBC22	Analog Input
14	LCBC23	Digital I/O and Power
14	LCBC24	Encoder Quadrature
15	LCBC25	Brake Air Pressure

Table 3

Callout	Cable Designator	Description
1	LRBC1	Drive Module Rotator Motor 0
1	LRBC2	Drive Module Rotator Motor 1
1	LRBC3	Drive Module Cable Chain Motor
2	LRBC4	Drive Module Rotator ENDAT Encoder 0
2	LRBC5	Drive Module Rotator ENDAT Encoder 1
2	LRBC6	Drive Module Cable Chain ENDAT Encoder
3	LRBC7	Drive Power Module Emergency Limits
4	LRBC8	Interface Module Rotator Absolute Encoders, Brake Sense
5	LRBC9	Interface Module Tape Read Heads, Relative position Sensor, 2 Aux 4-20ma Inputs
6	LRBC10	Interface Module Tape Excitation
7	LRBC11	J-Box Tape Read Head 0
7	LRBC12	J-Box Tape Read Head 1
8	LRBC13	J-Box Absolute CCW/CW Emergency Limits
9	LRBC14	J-Box Relative CCW/CW Emergency Limits
10	LRBC15	J-Box Brake Sense 0
10	LRBC16	J-Box Brake Sense 1
11	LRBC17	J-Box Relative Position Sensor
12	LRBC18	J-Box Absolute Encoder 0
12	LRBC19	J-Box Absolute Encoder 1
13	LRBC20	Drive Power Module Brake Release Solenoid
14	LRBC21	CAN Communication
14	LRBC22	Analog Input
14	LRBC23	Digital I/O and Power
14	LRBC24	Encoder Quadrature
15	LRBC25	Brake Air Pressure

Table 4

Callout	Cable Designator	Description
1	RFBC1	Drive Module Rotator Motor 0
1	RFBC2	Drive Module Rotator Motor 1
1	RFBC3	Drive Module Cable Chain Motor
2	RFBC4	Drive Module Rotator ENDAT Encoder 0

2	RFBC5	Drive Module Rotator ENDAT Encoder 1
2	RFBC6	Drive Module Cable Chain ENDAT Encoder
3	RFBC7	Drive Power Module Emergency Limits
4	RFBC8	Interface Module Rotator Absolute Encoders, Brake Sense
5	RFBC9	Interface Module Tape Read Heads, Relative position Sensor, 2 Aux 4-20ma Inputs
6	RFBC10	Interface Module Tape Excitation
7	RFBC11	J-Box Tape Read Head 0
7	RFBC12	J-Box Tape Read Head 1
8	RFBC13	J-Box Absolute CCW/CW Emergency Limits
9	RFBC14	J-Box Relative CCW/CW Emergency Limits
10	RFBC15	J-Box Brake Sense 0
10	RFBC16	J-Box Brake Sense 1
11	RFBC17	J-Box Relative Position Sensor
12	RFBC18	J-Box Absolute Encoder 0
12	RFBC19	J-Box Absolute Encoder 1
13	RFBC20	Drive Power Module Brake Release Solenoid
14	RFBC21	CAN Communication
14	RFBC22	Analog Input
14	RFBC23	Digital I/O and Power
14	RFBC24	Encoder Quadrature
15	RFBC25	Brake Air Pressure

Table 5

Callout	Cable Designator	Description
1	RCBC1	Drive Module Rotator Motor 0
1	RCBC2	Drive Module Rotator Motor 1
1	RCBC3	Drive Module Cable Chain Motor
2	RCBC4	Drive Module Rotator ENDAT Encoder 0
2	RCBC5	Drive Module Rotator ENDAT Encoder 1
2	RCBC6	Drive Module Cable Chain ENDAT Encoder
3	RCBC7	Drive Power Module Emergency Limits
4	RCBC8	Interface Module Rotator Absolute Encoders, Brake Sense
5	RCBC9	Interface Module Tape Read Heads, Relative position Sensor, 2 Aux 4-20ma Inputs
6	RCBC10	Interface Module Tape Excitation
7	RCBC11	J-Box Tape Read Head 0
7	RCBC12	J-Box Tape Read Head 1
8	RCBC13	J-Box Absolute CCW/CW Emergency Limits
9	RCBC14	J-Box Relative CCW/CW Emergency Limits
10	RCBC15	J-Box Brake Sense 0
10	RCBC16	J-Box Brake Sense 1
11	RCBC17	J-Box Relative Position Sensor
12	RCBC18	J-Box Absolute Encoder 0
12	RCBC19	J-Box Absolute Encoder 1
13	RCBC20	Drive Power Module Brake Release Solenoid
14	RCBC21	CAN Communication
14	RCBC22	Analog Input

14	RCBC23	Digital I/O and Power
14	RCBC24	Encoder Quadrature
15	RCBC25	Brake Air Pressure

Table 6

Callout	Cable Designator	Description
1	RRBC1	Drive Module Rotator Motor 0
1	RRBC2	Drive Module Rotator Motor 1
1	RRBC3	Drive Module Cable Chain Motor
2	RRBC4	Drive Module Rotator ENDAT Encoder 0
2	RRBC5	Drive Module Rotator ENDAT Encoder 1
2	RRBC6	Drive Module Cable Chain ENDAT Encoder
3	RRBC7	Drive Power Module Emergency Limits
4	RRBC8	Interface Module Rotator Absolute Encoders, Brake Sense
5	RRBC9	Interface Module Tape Read Heads, Relative position Sensor, 2 Aux 4-20ma Inputs
6	RRBC10	Interface Module Tape Excitation
7	RRBC11	J-Box Tape Read Head 0
7	RRBC12	J-Box Tape Read Head 1
8	RRBC13	J-Box Absolute CCW/CW Emergency Limits
9	RRBC14	J-Box Relative CCW/CW Emergency Limits
10	RRBC15	J-Box Brake Sense 0
10	RRBC16	J-Box Brake Sense 1
11	RRBC17	J-Box Relative Position Sensor
12	RRBC18	J-Box Absolute Encoder 0
12	RRBC19	J-Box Absolute Encoder 1
13	RRBC20	Drive Power Module Brake Release Solenoid
14	RRBC21	CAN Communication
14	RRBC22	Analog Input
14	RRBC23	Digital I/O and Power
14	RRBC24	Encoder Quadrature
15	RRBC25	Brake Air Pressure

6. Direct Gregorian Rotators

Figure 2 shows the electrical connections for 1 axis of a direct Gregorian instrument rotator and cable chain. Table 7 through Table 8 list the cables required for connection of the electrical equipment on direct Gregorian rotators.

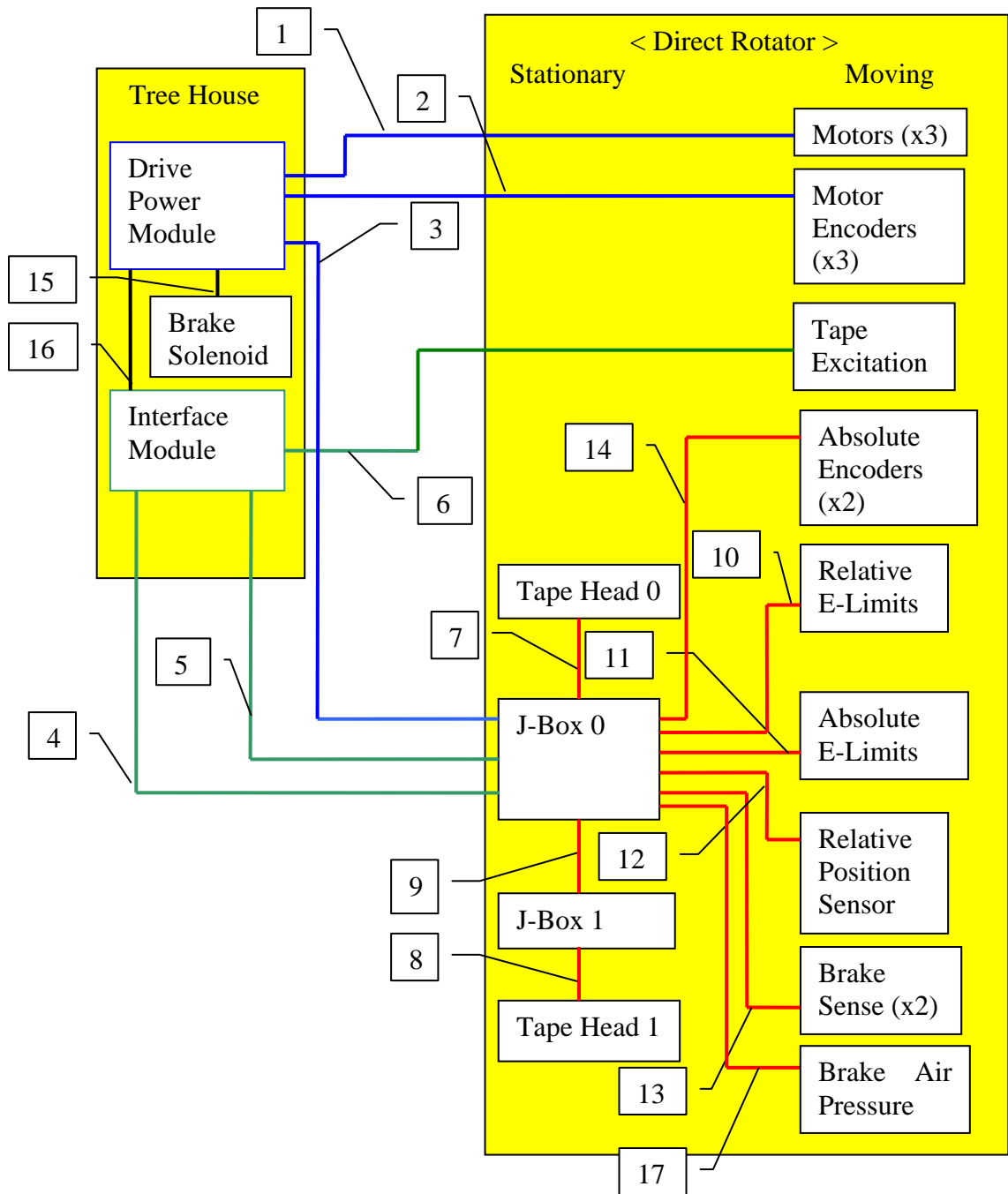

Figure 2

Cable Designator - (L/R)(F/C/R)(B/D)(Cable Number)

Table 7

Callout	Cable Designator	Description
1	LDC1	Drive Module Rotator Motor 0
1	LDC2	Drive Module Rotator Motor 1
1	LDC3	Drive Module Cable Chain Motor
2	LDC4	Drive Module Rotator ENDAT Encoder 0
2	LDC5	Drive Module Rotator ENDAT Encoder 1
2	LDC6	Dive Module Cable Chain ENDAT Encoder
3	LDC7	Drive Power Module Emergency Limits
4	LDC8	Interface Module Rotator Absolute Encoders, Brake Sense
5	LDC9	Interface Module Tape Read Heads, Relative position Sensor, Pressure Transducer, 2 Aux 4-20ma Inputs
6	LDC10	Interface Module Tape Excitation
7	LDC11	J-Box 0 Tape Read Head 0
8	LDC12	J-Box 1 Tape Read Head 1
9	LDC13	J-Box 0 J-Box 1
10	LDC14	J-Box 0 Relative CCW/CW Emergency Limits
11	LDC15	J-Box 0 Absolute CCW/CW Emergency Limits
12	LDC16	J-Box 0 Relative Position Sensor
13	LDC17	J-Box 0 Brake Sense 0
13	LDC18	J-Box 0 Brake Sense 1
14	LDC19	J-Box 0 Absolute Encoder 0
14	LDC20	J-Box 0 Absolute Encoder 1
15	LDC21	Drive Power Module Brake Release Solenoid
16	LDC22	CAN Communication
16	LDC23	Analog Input
16	LDC24	Digital I/O and Power
16	LDC25	Encoder Quadrature
17	LDC26	Brake Air Pressure

Table 8

Callout	Cable Designator	Description
1	RDC1	Drive Module Rotator Motor 0
1	RDC2	Drive Module Rotator Motor 1
1	RDC3	Drive Module Cable Chain Motor
2	RDC4	Drive Module Rotator ENDAT Encoder 0
2	RDC5	Drive Module Rotator ENDAT Encoder 1
2	RDC6	Dive Module Cable Chain ENDAT Encoder
3	RDC7	Drive Power Module Emergency Limits
4	RDC8	Interface Module Rotator Absolute Encoders, Brake Sense
5	RDC9	Interface Module Tape Read Heads, Relative position Sensor, 2 Aux 4-20ma Inputs
6	RDC10	Interface Module Tape Excitation

7	RDC11	J-Box 0 Tape Read Head 0
8	RDC12	J-Box 1 Tape Read Head 1
9	RDC13	J-Box 0 J-Box 1
10	RDC14	J-Box 0 Relative CCW/CW Emergency Limits
11	RDC15	J-Box 0 Absolute CCW/CW Emergency Limits
12	RDC16	J-Box 0 Relative Position Sensor
13	RDC17	J-Box 0 Brake Sense 0
13	RDC18	J-Box 0 Brake Sense 1
14	RDC19	J-Box 0 Absolute Encoder 0
14	RDC20	J-Box 0 Absolute Encoder 1
15	RDC21	Drive Power Module Brake Release Solenoid
16	RDC22	CAN Communication
16	RDC23	Analog Input
16	RDC24	Digital I/O and Power
16	RDC25	Encoder Quadrature
17	RDC26	Brake Air Pressure

	Instrument Rotator and Cable Chain Electrical Connection Manual	Doc.No : 675s008 Issue : a Date : 13-Mar-2007	Page 14
--	--	---	---------

Doc_info_start

Title: Instrument Rotator and Cable Chain Electrical Connection Manual

Document Type: *Specification / Technical Report / Technical Manual*

Source: Steward Observatory

Issued by: *Michael Gusick*

Date_of_Issue: *13 March 2007*

Revised by:

Date_of_Revision:

Checked by:

Date_of_Check:

Accepted by:

Date_of_Acceptance:

Released by:

Date_of_Release:

File Type: MS Word

Local Name:

Category: *675*

Sub-Category: *008*

Assembly: *Instrument Rotator and Cable Chain*

Sub-Assembly:

Part Name:

CAN Designation: *675s008*

Revision: *a*

Doc_info_end